

4. ENGINE ELECTRICAL  
MPFI MODEL (NA)

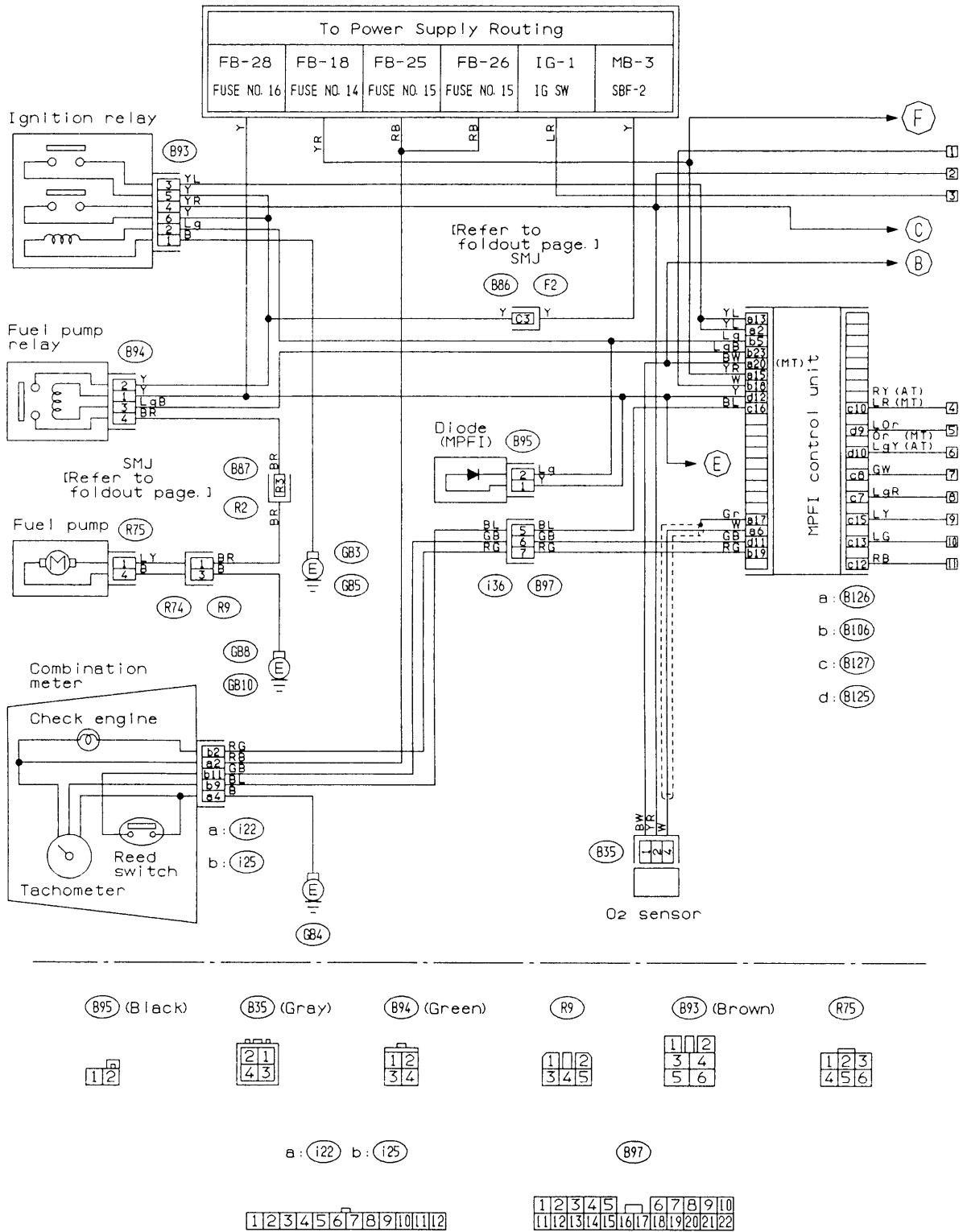

BR10-03A

Fig. 29-1

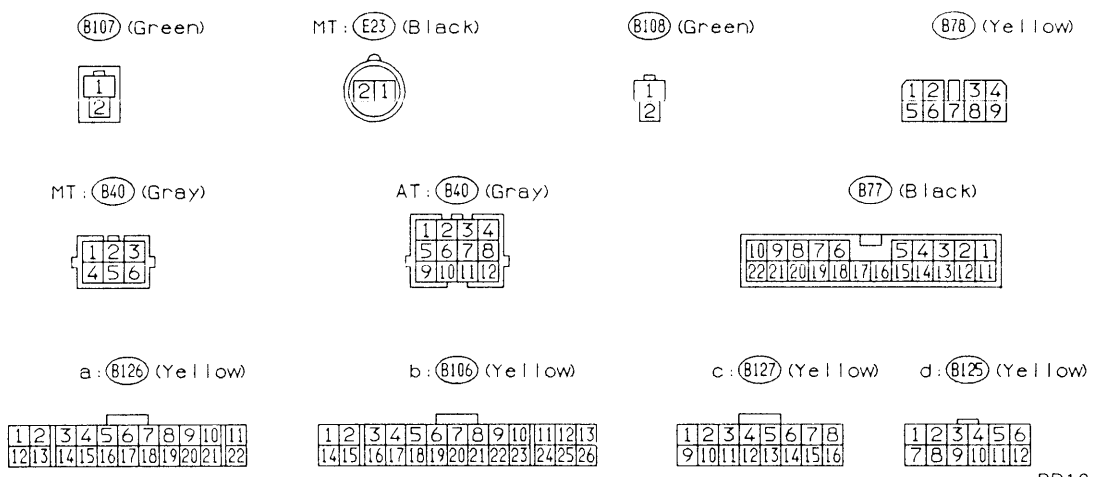
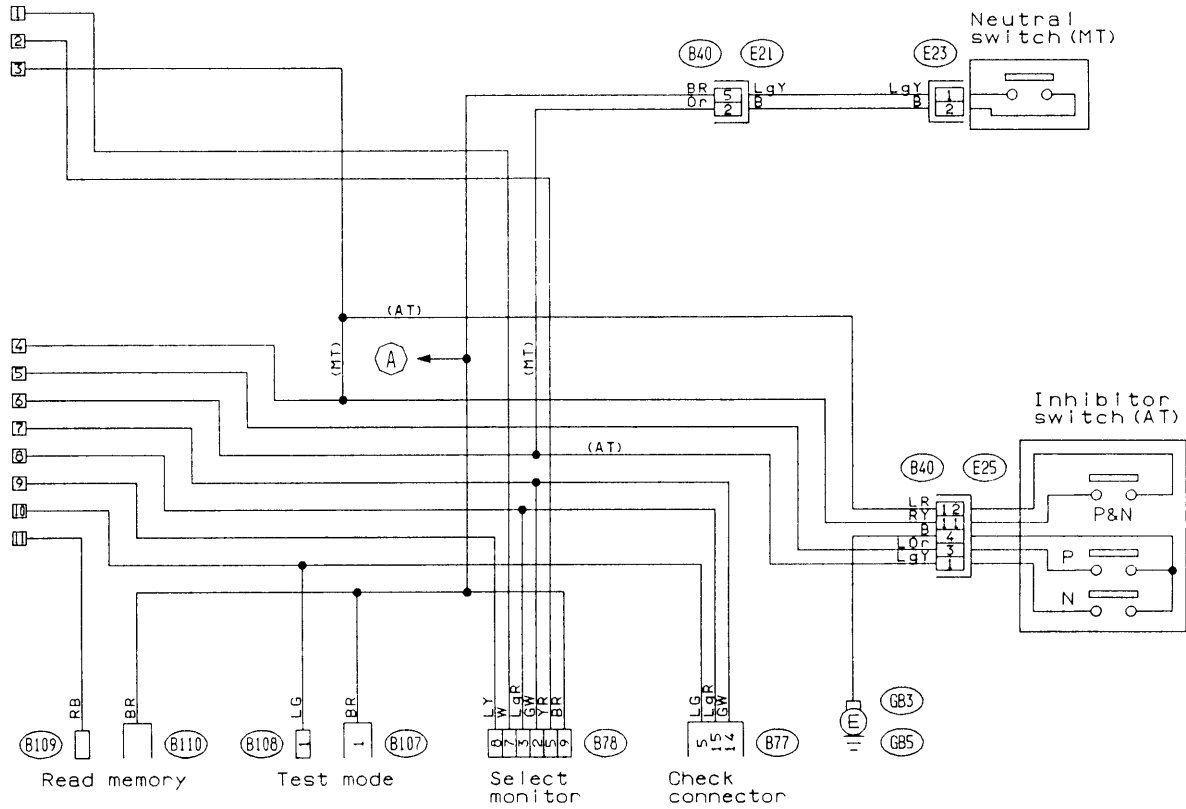

BR10-03B

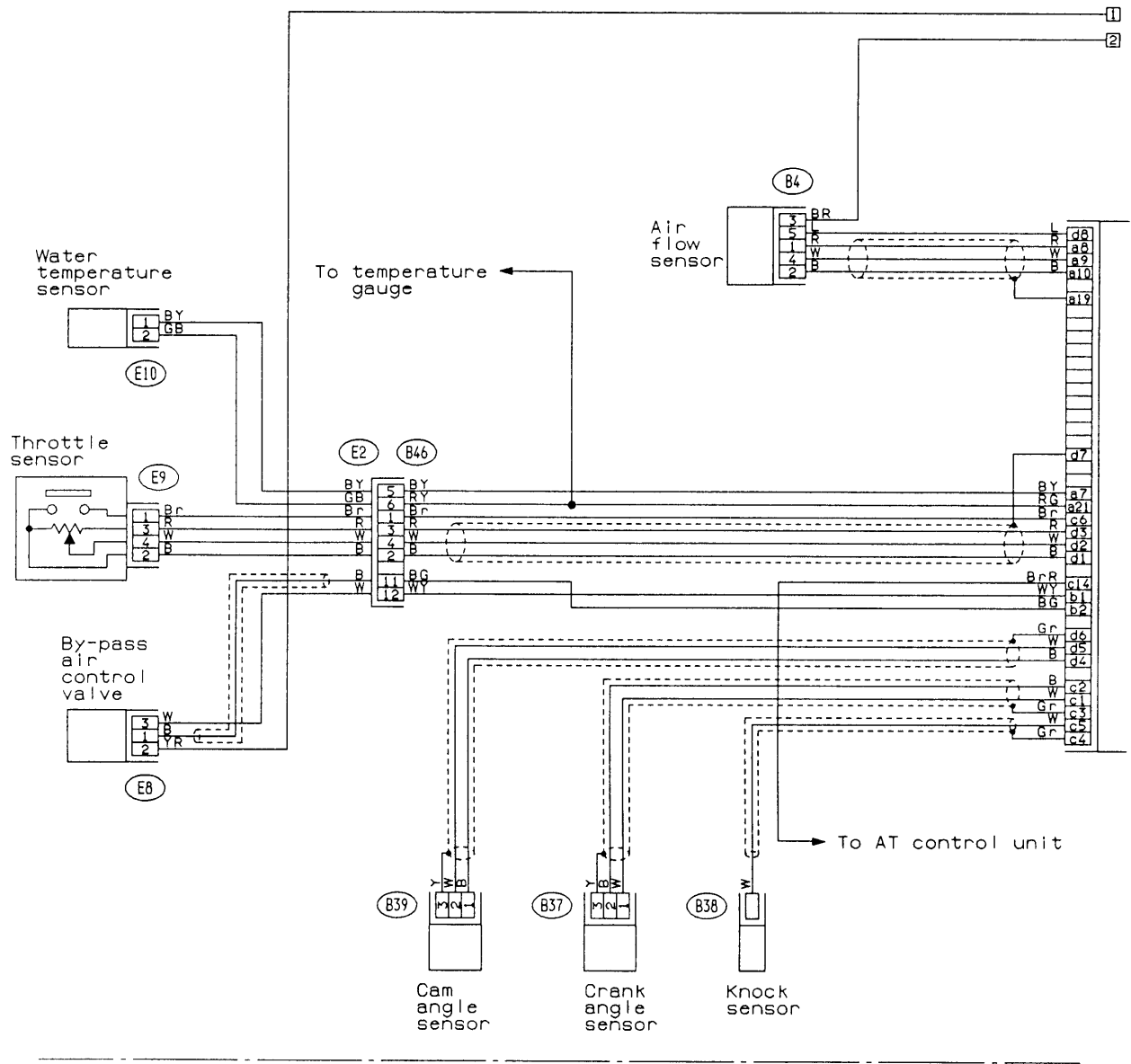

- (E10) (Brown)
- (B37) (Gray)
- (B39) (Gray)
- (E9) (Gray)
- 1 2
- 1 2 3
- 1 2 3
- 1 2 3 4
- (B4) (Gray)
- (B46) (Gray)
- 1 2 3 4
- 5 6 7 8
- 9 10 11 12

BR10-03C

Fig. 29-2

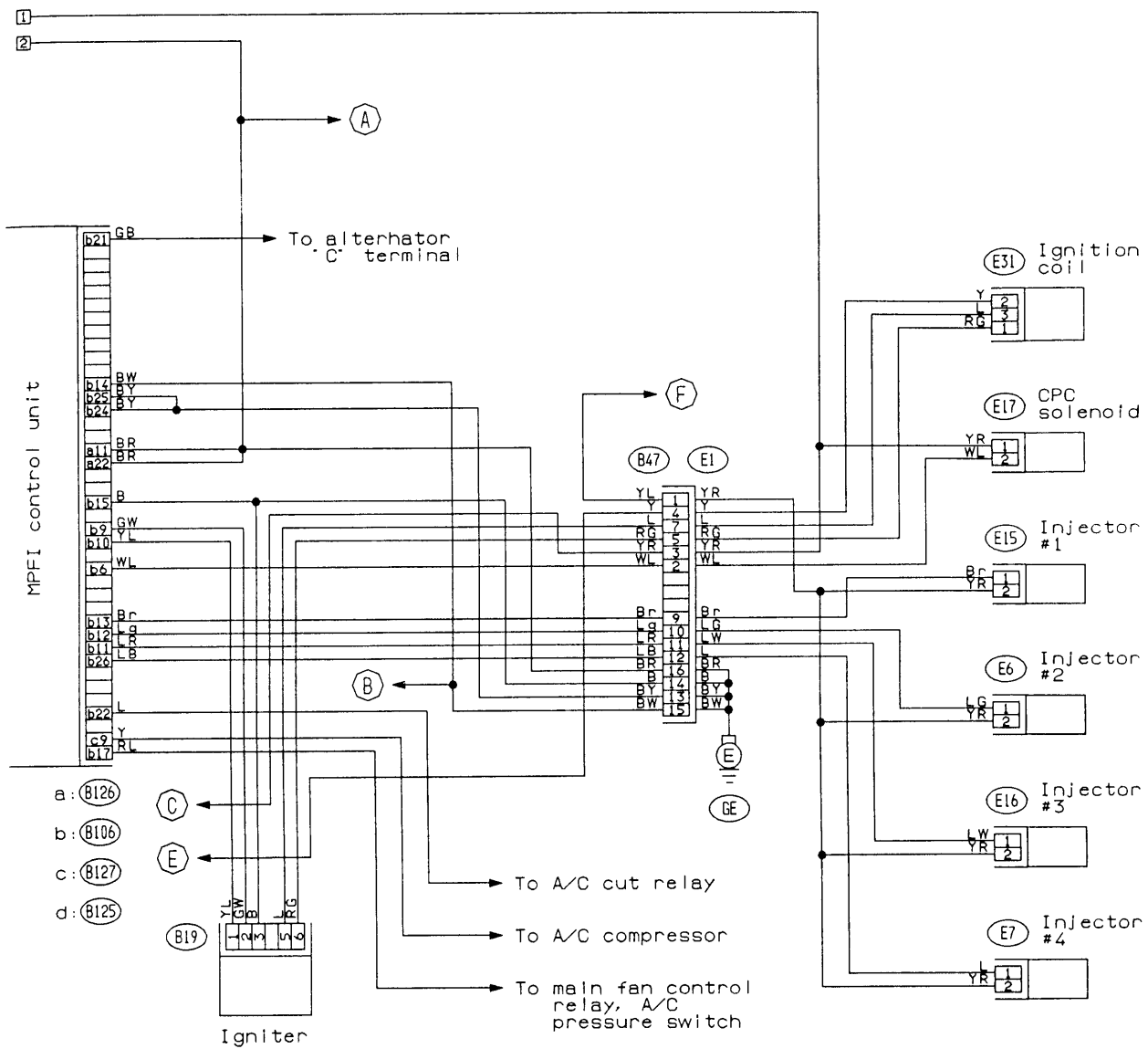

- E6 (Gray)
- E17 (Blue)
- E7 (Gray)
- E16 (Gray)
- E15 (Gray)
- E31 (Gray)
- B19 (Gray)

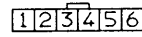

a: B126 (Yellow)

b: B106 (Yellow)

c: B127 (Yellow)

d: B125 (Yellow)

(Gray)  
B47

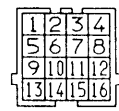
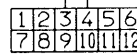
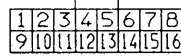
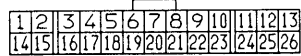
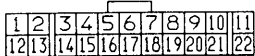

BR10-03D

MPFI MODEL (TURBO)

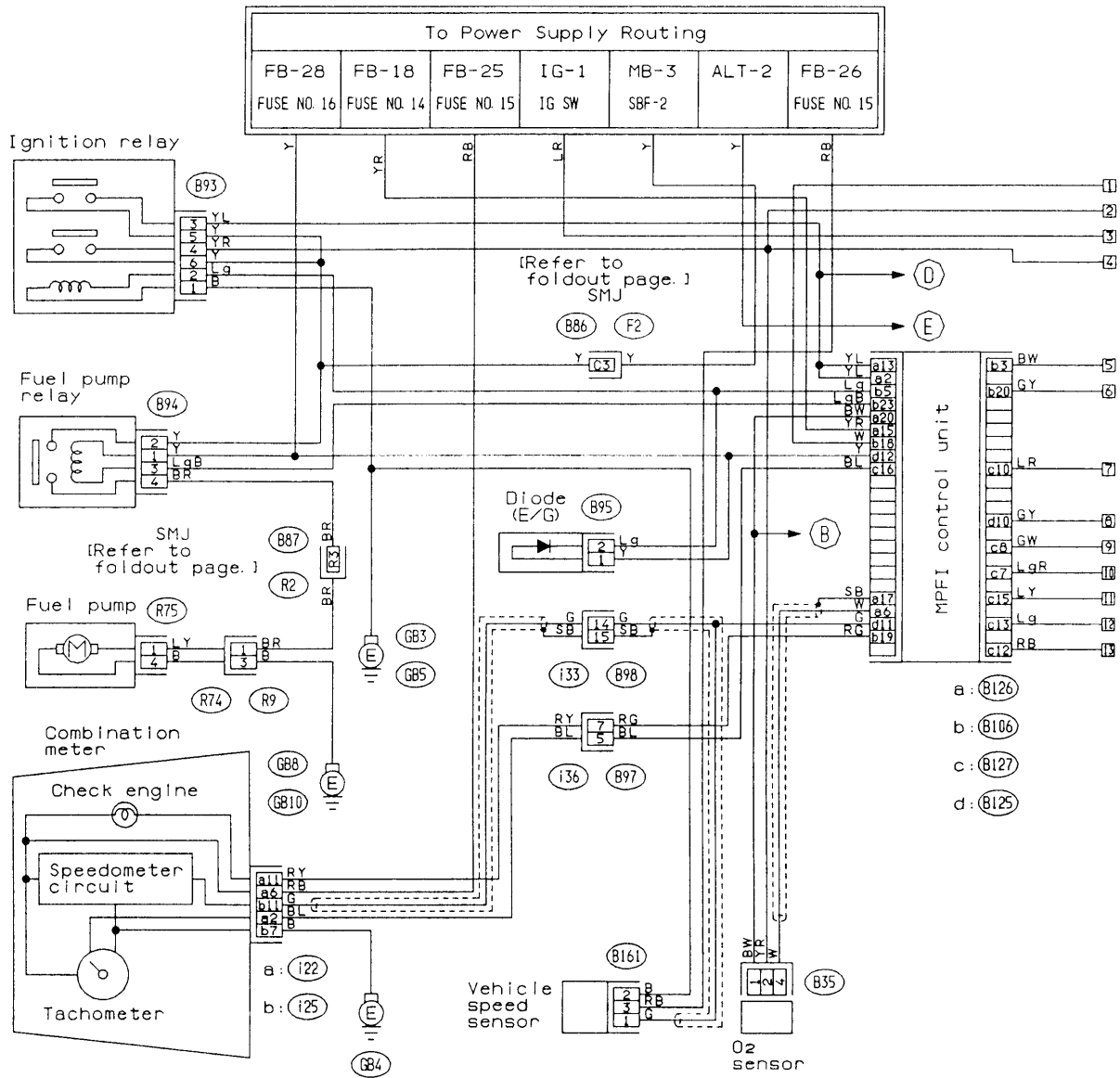

- (B95) (Black)
  - (B35) (Gray)
  - (B94) (Green)
  - (R9)
  - (B93) (Brown)
  - (R75)
- |   |   |
|---|---|
| 1 | 2 |
| 3 | 4 |

2	1
4	3

1	2
3	4

1	2
3	4
5	6

1	2	3
4	5	6
- a: (122)    b: (125)
- (B97)

(B98) (Blue)
- (B161)
- |    |    |    |    |    |    |    |    |    |    |    |    |
|----|----|----|----|----|----|----|----|----|----|----|----|
| 1  | 2  | 3  | 4  | 5  | 6  | 7  | 8  | 9  | 10 |    |    |
| 11 | 12 | 13 | 14 | 15 | 16 | 17 | 18 | 19 | 20 | 21 | 22 |
- |   |   |   |
|---|---|---|
| 1 | 2 | 3 |
|---|---|---|

BR10-04A

Fig. 30-1

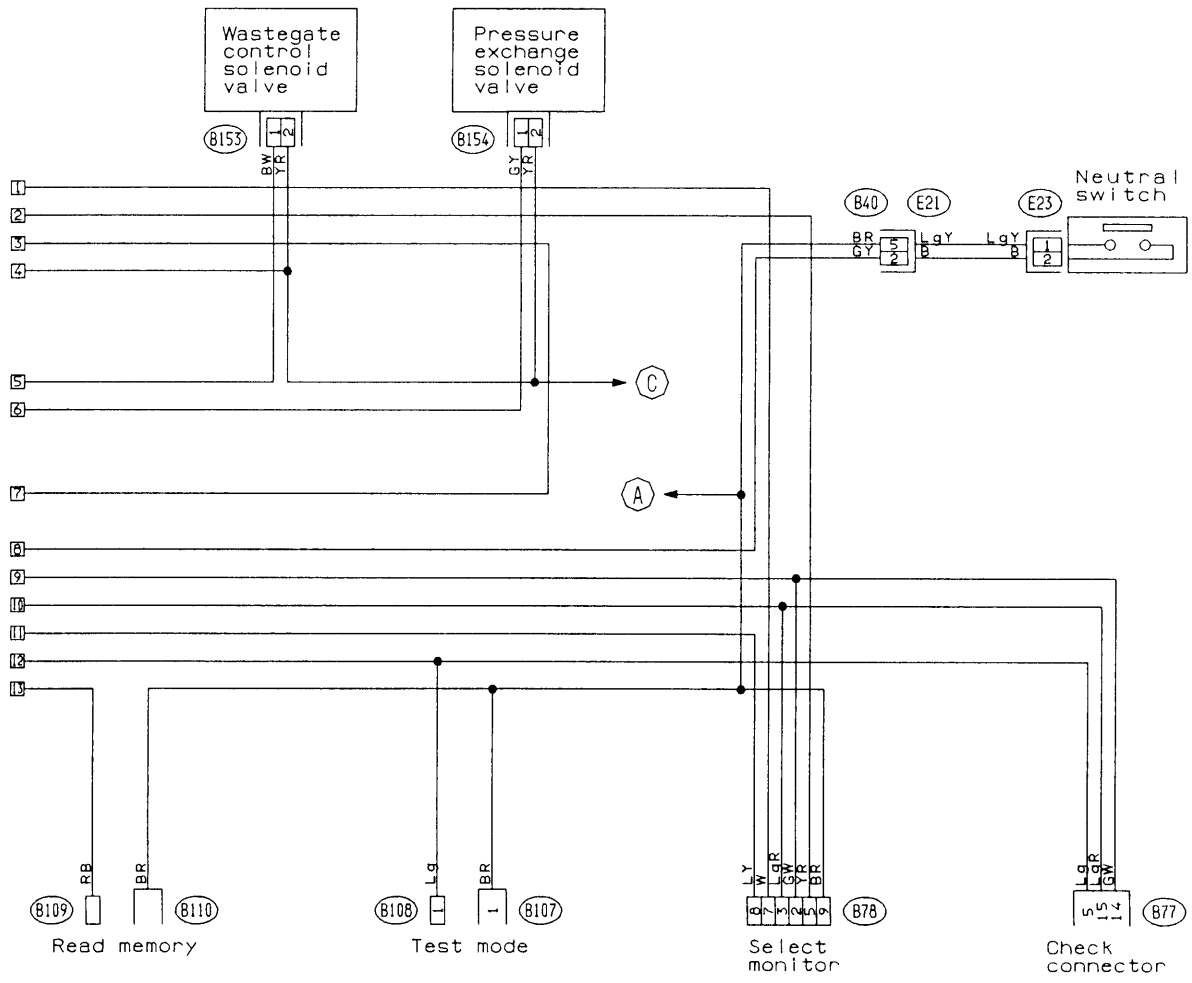

- (B107) (Green)
- (E23) (Black)
- (B108) (Green)
- (B78) (Yellow)
- (B153) (Black)
- (B40) (Gray)
- (B77) (Black)
- (B154) (Brown)
- a: (B126) (Yellow)
- b: (B106) (Yellow)
- c: (B127) (Yellow)
- d: (B125) (Yellow)

BR10-04B

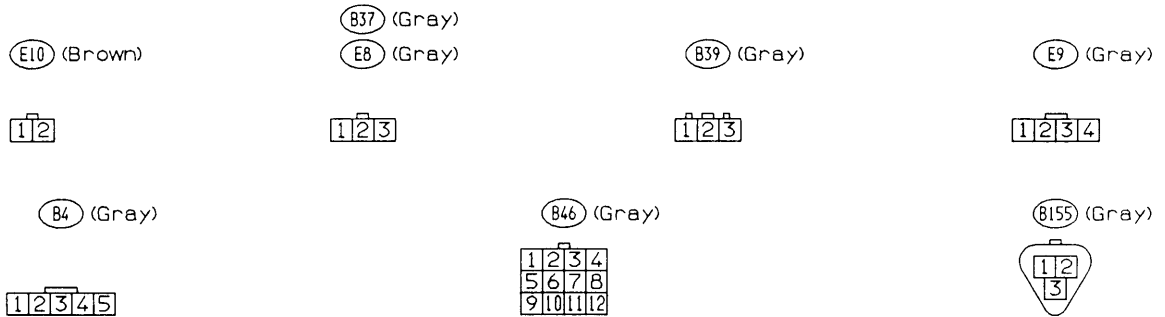
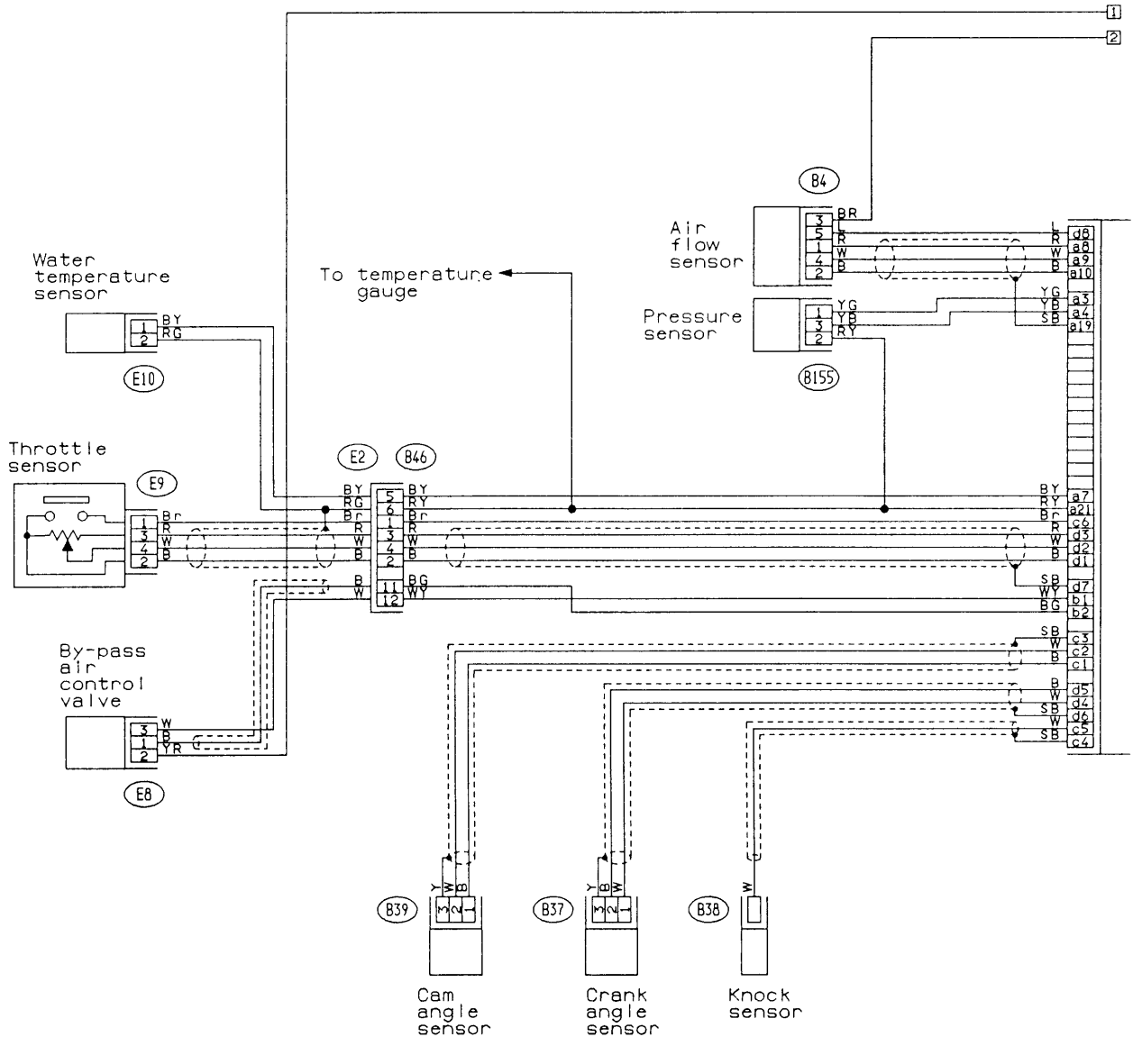

BR10-04C

Fig. 30-2

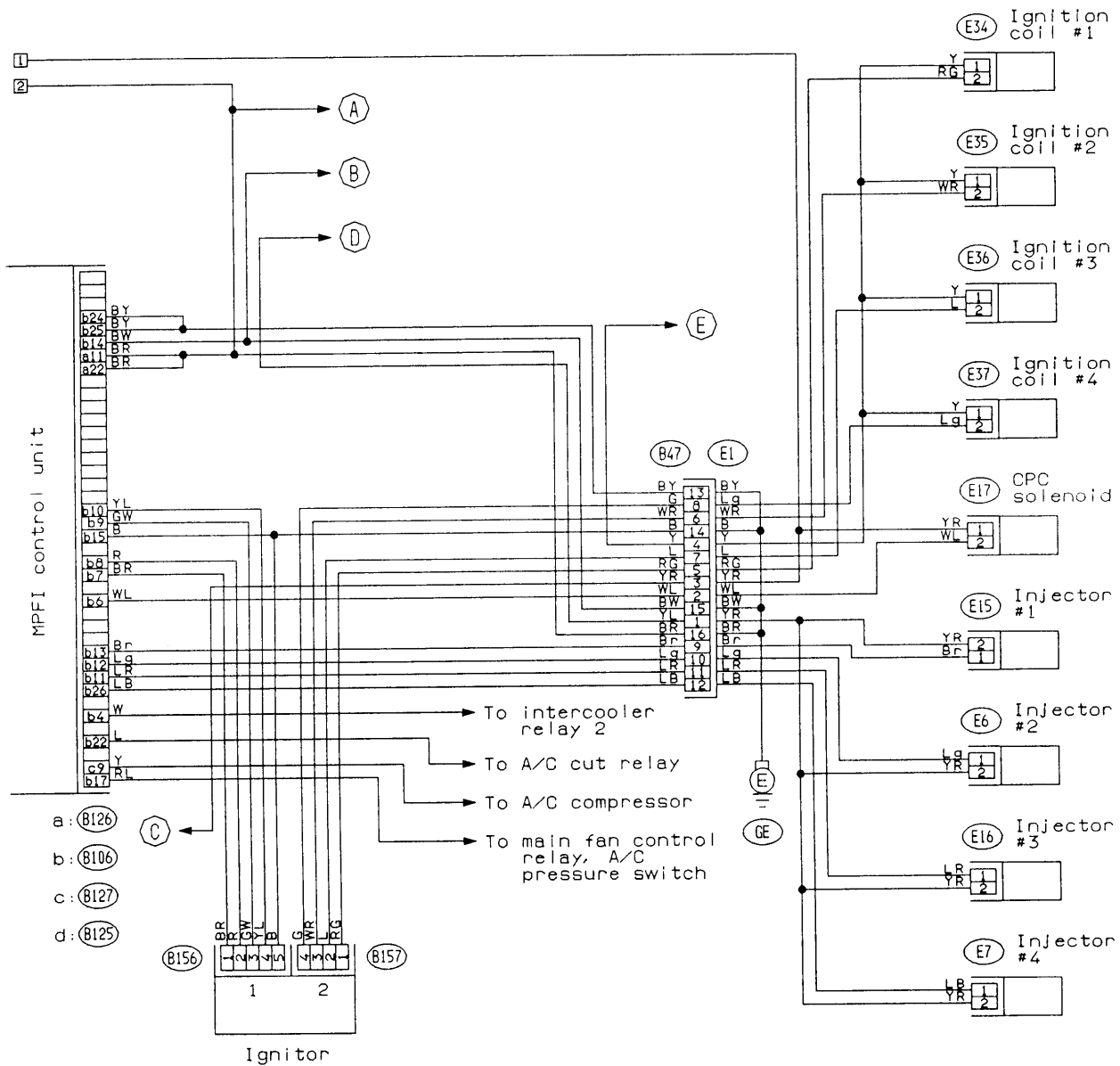

- (E6) (Gray) (E17) (Blue) (E21) (Gray)
- (E7) (Gray) (E16) (Gray) (E15) (Gray)
- (E18) (Gray) (E19) (Gray) (E20) (Gray)

(B156) (Gray)

(B157) (Gray)

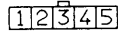

a: (B126) (Yellow)

b: (B106) (Yellow)

c: (B127) (Yellow)

d: (B125) (Yellow)

(B47) (Gray)

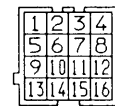
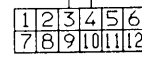
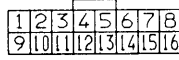
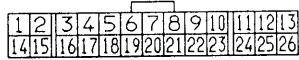
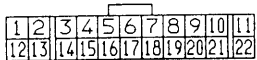

BR10-04D